

Transira™ Motorized Shade Accessory Sash in 3350 Frame Product Details - Casement Configuration w/ 1" Insulated Glazing

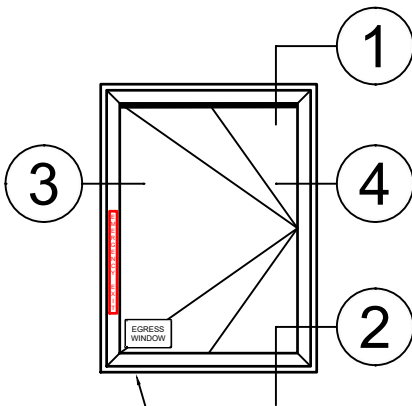

Note: Multiple configurations of this window system are available. Refer to the WINCO website for additional options or contact your local WINCO Sales Representative for information.

WINCO RESERVES THE RIGHT TO MODIFY OR CHANGE INFORMATION WITHIN THIS BOOK WHEN DEEMED NECESSARY FOR PRODUCT IMPROVEMENT



Vent can be configured to meet NFPA 101 requirements for use as Means of Secondary Egress if Minimum size limits are met.

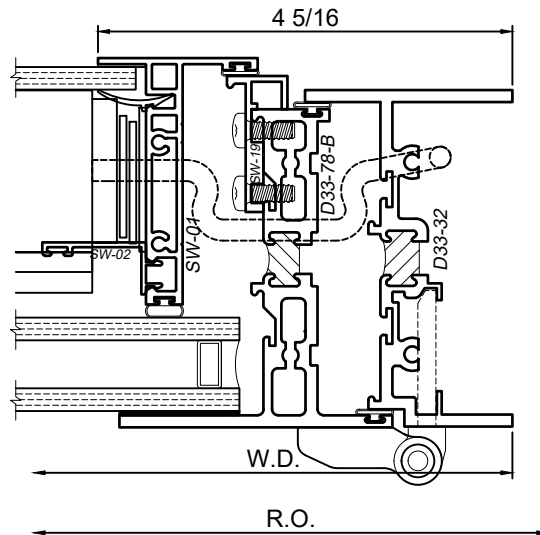
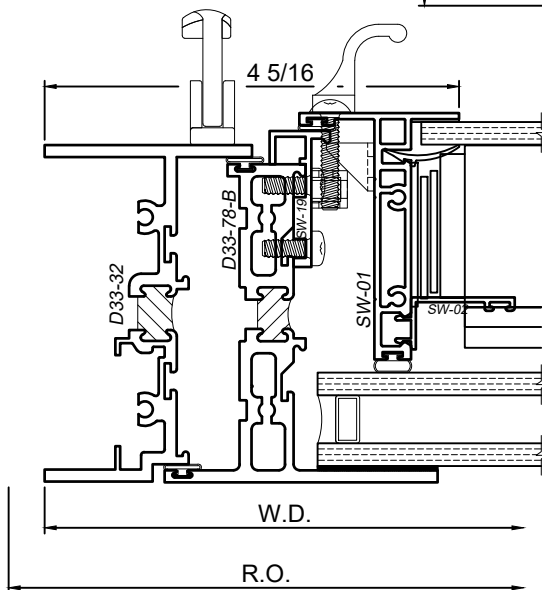
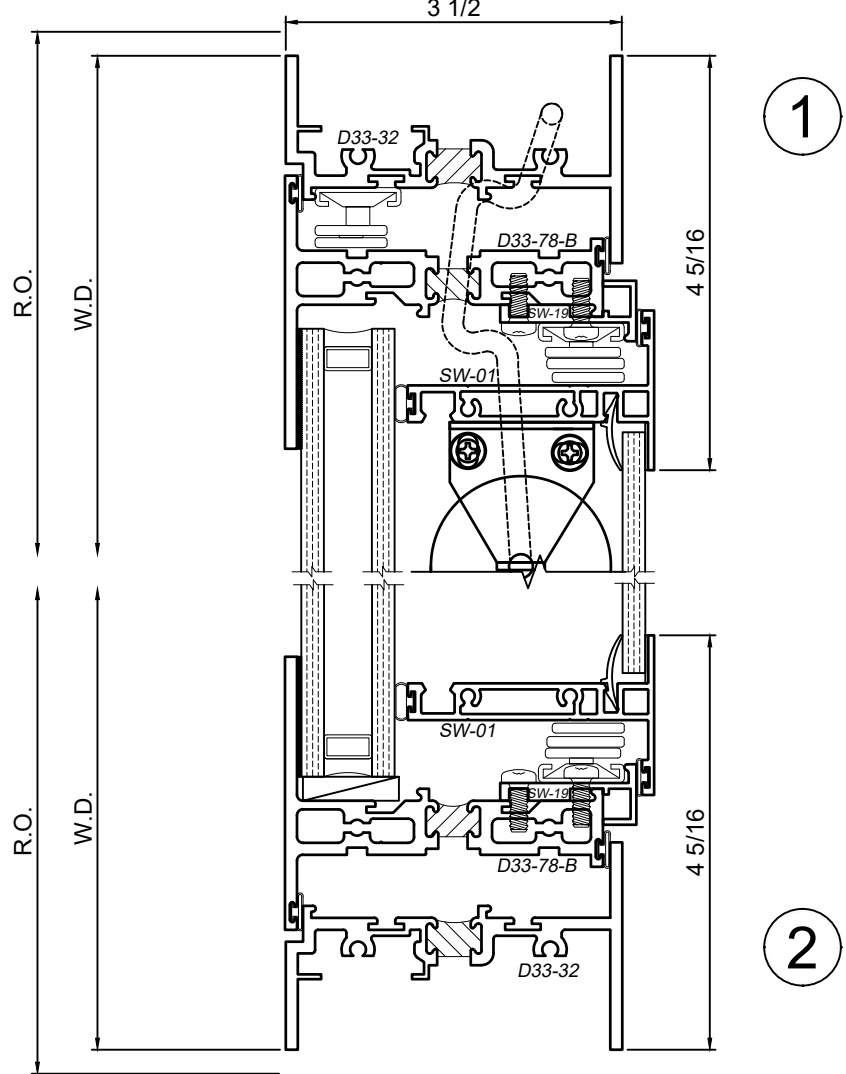

SCALE 6"=1'-0"

3

4